

Ziyinet Ondogan,  
Cetin Erdogan

Ege University, Engineering Faculty,  
Textile Engineering Department,  
35100 Bornova-Izmir, TURKEY  
Phone: 00.90.532.285 84 34  
Fax: 00.90.232.339 92 22  
E-mail: ondoganz@egenet.com.tr  
E-mail: erdogan@textil.ege.edu.tr

# The Comparison of the Manual and CAD Systems for Pattern Making, Grading and Marker Making Processes

## Abstract

*The objective of this research is to conduct a comparison in pattern and marker making between the CAD and manual methods as regards individual course steps and total time values, and to determine the effective of model complexity on these times. For this purpose, four models starting from the simplest to the most complex were designed, and the course steps of the traditional manual method and CAD were first established. Each course step was carried out repeatedly by an expert according to statistical norms. In order to determine in which steps and for which model CAD can be more productive, the data obtained for both methods was compared with respect to the individual time value of each course step and the total time values. Furthermore, the possible causes of the results obtained were discussed and suggestions were put forward.*

**Keywords:** development of CAD, functions of CAD, model complexity, pattern making, marker making.

## ■ Introduction

Devices performing high-tech services in the apparel industry are commonly referred to as 'CAD/CAM'. In the apparel industry, CAD systems are mainly used in various processes such as garment design, pattern preparation, pattern grading and marker making. CAM systems include computerised sewing machines, fabric spreading & cutting systems, and mover systems used during the sewing process of apparel production [14].

While computerised sewing machines, spreading systems, cutting machines and mover mechanisms provide a highly technological support during the production phase, CAD systems are extensively used during the preproduction phase, which is labour-intensive [16].

During the design and production phases, CAD/CAM systems indirectly improve the productivity and efficiency of companies by contributing to the integration and automation processes. CAD/CAM constitutes the technological infrastructure of the concept of 'CIM', which has been described as 'the factory of the future' [2].

## ■ Development of CAD systems

In the 1960s, several brands of computers were introduced onto the market, and textile engineers started to think about CAD. These machines, called mainframes, were gigantic devices. Punch-cards were prepared and then processed in the computer using the technology of the time. The result of the work that was ordered could only be obtained the next

day, or sometimes the following week. These methods, such as transforming the work of the designer into the punches on the cards and arranging their positions in jacquard weaves and knits, required long and arduous efforts during routine textile processes. This process was first put into practice at MIT in the years 1963-4. In the beginning, the data was loaded onto central computers simultaneously. After some time, graphic terminals were developed, which proved to be a great help. The real development, on the other hand, which paved the way for creative designing, started with the introduction of interactive computers. Mini-computers started to be used by small groups of people, and our modern-day PCs formed strong networks with one another. It became possible to see on the screen what the designer had in mind at a period no later than the time he would have spent if he had drawn the whole design himself. Now, designers had no excuse not to make use of the creative changes provided by this favourable environment [8].

By the end of 1993, many CAD/CAM vendors had automatic marker-making capability. However, much work remains to be done, due to the heuristic nature of the process. The technique is only employed for costing purposes, with the interactive method being the choice for production markers. A programme that enables an automatic marker-making system to compact patterns (by placing the pattern pieces as closely together as possible) in only 30-45 seconds has been developed. This programme compacts markers automatically in less time, almost as efficiently as an operator does.

However, it needs some corrections by the operator so as to improve cutting quality and fabric usage productivity [7]. Today, the three-dimensional body scanner is a promising new technology that will contribute revolutionary changes to the conception, design, manufacture and distribution of apparel. Currently, the quantification of fit is complex and ambiguous, and objective methods, such as comparison of linear measurements, are inadequate. Body scanning provides multi-dimensional data that can provide new insights into sizing and grading systems [3].

The 3D PDS system, developed for 3D pattern designing, originates from the shape of the body. It is possible to apply not only a standard mannequin within the system, but also models selected or created by the user. Thus, more suitable body measurements can be applied for made-to-measure garments [20].

How functional the related software is affects the continuation of development. Tendencies are mostly towards automated garment development from body scan data. For body scanning to support automated garment development, automatic integration of measurement data into commercially available CAD/CAM software must be achieved first. To date, body scan data does not automatically integrate with any commercially available CAD/CAM system or measurement extraction algorithmic process. The lack of standard formats for transmitting body scan data further impedes the process, in that a recipient of body scan data cannot currently be assured that the critical

measurements needed for the product design have been appropriately extracted. The principle of this research, to link critical garment sizing measurements with critical anthropometric measurements extracted from body scans, is planned as a three-year investigation. In years 2 and 3 we will move toward the development and activation of the model, culminating in the creation of the integration linkage necessary for Automated Garment Development [5].

## Material

The material for this study consists of garment models, patterns, transparent pattern papers, cardboards, CAD systems, a chronometer and fabrics.

## Garment Models

A basic t-shirt was chosen as a model, due to the fact that it is manufactured widely in small-, medium- and large-scale companies in the apparel sector, and that it is in constant demand on the market throughout the year.

Starting with the basic t-shirt, a total of four t-shirt models were worked on and graded, increasing the number of pieces for each model steadily. As can be seen



Figure 1. Model 1.

below, the number of pieces were arranged so as to increase the numbers steadily;

- Model 1; consists of 5 pieces (Figure 1),
- Model 2; consists of 7 pieces (Figure 2),
- Model 3; consists of 9 pieces (Figure 3),
- Model 4; consists of 11 pieces (Figure 4).

## Garment patterns

Patterns belonging to all models were prepared according to the steps shown below;

- Main size pattern preparation,
- Grading of main size patterns,
- Different sizes separated by copying nest sizes on transparent pattern papers,
- Cardboard patterns obtained by transferring these transparent patterns on cardboard.

## Fabrics

All fabrics are without pattern. The fabric parameters are as stated below:

- 120 g/m<sup>2</sup> in weight, 88 cm in width, 100% cotton 30/1 single jersey tubular fabric,
- 120 g/m<sup>2</sup> in weight, 120 cm in width, 100% cotton 30/1 single jersey open width fabric,
- 140 g/m<sup>2</sup> in weight, 45 cm in width, 100% cotton 30/1 1×1 rib tubular fabric.



Figure 2. Model 2.

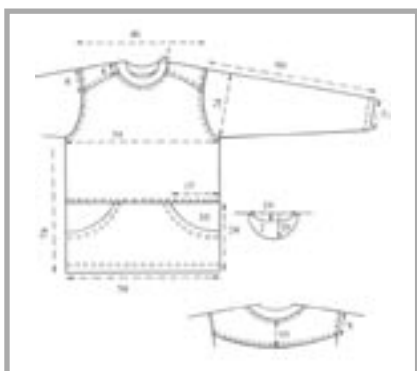

Figure 3. Model 3.



Figure 4. Model 4.

## CAD systems

Five different CAD systems were used to obtain the findings: Assyst, Gerber, Investronica, Konsan, Lectra.

## Methodology

Evaluation Research aims to demonstrate to what extent previously stated targets have been reached within the unity of the research by trying to determine the relationship among input, output, process and performance variables in the studies being carried out [10].

Considering the fact that this research includes analytic assessments, the Evaluation Survey Methodology was chosen, as it is the most suitable method for the objective direction, application studies and data evaluation of the research.

Technical drawings and size set tables of the basic t-shirt which form the material of this research were prepared by the author. These technical drawings are proportional and equipped with necessary measurements, sewing instructions and fabric varieties for the preparation of garment patterns.

Two methods were applied to obtain the findings in the research, the manual method and the CAD method. Then, the stages for carrying out the research were determined. On this basis the procedures forming the research were also established [18]. These were determined separately for the manual and CAD working methods.

Either of the two procedures stated below can be followed to work the model with the CAD system:

- 1- Digitising the main size patterns after preparing them manually,
- 2- Preparing from the beginning of the main size patterns using CAD.

To follow the latter procedure, CAD system operators have to be good pattern designers at the same time. This is not a frequently encountered situation in the apparel industry. Mostly, the main size patterns are prepared manually and then digitised by following the former procedure in the industry.

In this research, the main size patterns were prepared manually by the author to be digitised, due to the fact that a method similar to the course of the work in the industry was used.

**Table 1.** Stages and procedures for the manual working method.

Number of stage	Stages	Procedures
1.	Main size pattern preparation	-
2.	Main size pattern checking and correction	A. Measurement check B. Checking of face to face sewing places C. Main size pattern correction
3.	Putting necessary allowances on patterns	A. Production gathering allowances B. Shrinkage allowances C. Seam allowances
4.	Main size pattern size setting	-
5.	Size set patterns check and correction	A. Measurement check B. Checking of face to face sewing places C. Correction of size set patterns
6.	Arrangements prior to marker making	A. Separation of sizes of nested patterns B. Cutting of patterns on transparent papers C. Checking of patterns on transparent papers D. Correction of patterns on transparent papers E. Transferring patterns on transparent papers to cardboard F. Checking the patterns on cardboard G. Correcting the patterns on cardboard H. Cutting the patterns on cardboard
7.	Marker making and correction	A. Fabric and rib marker making B. Checking and correcting fabric and rib marker
8.	Marker plotting	A. Fabric marker plotting B. Rib marker plotting

**Table 2.** Stages and procedures for the CAD system working method.

Number of stage	Stages	Procedures
1.	Main size pattern preparation	A. Main size pattern preparation manually B. Digitising main size patterns
2.	Main size pattern checking and correction	A. Measurement check B. Checking of face to face sewing places C. Main size pattern correction
3.	Putting necessary allowances on patterns	A. Production gathering allowances B. Shrinkage allowances C. Seam allowances
4.	Main size pattern size setting	-
5.	Size set patterns check and correction	A. Measurement check B. Checking of face to face sewing places C. Correction of size set patterns
6.	Arrangements prior to marker making	A. Model file preparation B. Order file preparation
7.	Marker making and correction	A. Fabric and rib marker making B. Fabric and rib marker check and correction
8.	Marker plotting	A. Fabric marker plotting B. Rib marker plotting

The research was carried out in two directions: In the first direction, the manual method was compared with the CAD method to investigate the effects of model complexity. The course steps and procedures for the model chosen were applied both manually and by the CAD method. The course steps and procedures for the manual method were realised by the author. Those for the CAD method were realised by an expert CAD system operator.

During the studies carried out in the second direction, the aim was to compare the manual method with the CAD method separately for each stage value and the total values. At this point only the 'Model-1' was handled, and related stages and procedures were conducted 5 times by 5 different expert pattern designers and pattern technicians, and 5 times by 5 different expert CAD system operators and operator assistants by using five different CAD systems.

The pattern designers had 15-20 years of experience in the industry, and were capable of preparing patterns on all kinds of models. The pattern technicians chosen had the same level of experience and expertise as their colleagues in the industry. The CAD system operators were chosen from among people who had good command of patterns and the CAD system. The required duties were presented to both groups in the form of a list of in-

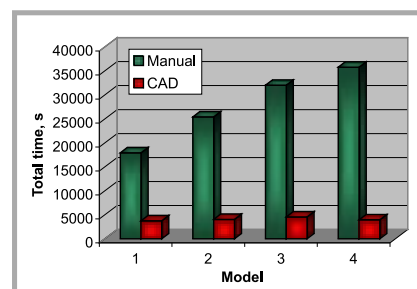

**Figure 5.** Comparison of the manual and CAD methods (4 Models).

structions by the author, and the work was carried out under her supervision.

Two procedures were followed to obtain findings in the research. The stages and procedures for the manual working method are shown in Table 1.

Stages and procedures for the CAD working method are shown in Table 2.

Each course step was timed by a digital chronometer while carrying out the timing process; human activity and the usage of production instruments for the person doing the work (or the production instrument being used) were also taken into consideration [19]. Based on these usage times and activities, timings were also taken for the 'Main Activity' and 'Alternative Activity', & the 'Main Usage' and 'Alternative Usage'.

The concept of production loss is often expressed in terms of losses suffered due to a failure to obtain appropriate and profitable returns from the investment. The three kinds of losses experienced in industrial establishments are losses in work power, production activities, raw materials and accessories [4].

Similar losses are also observed in the apparel sector. The share of raw materials and accessories, which are the main items of the apparel industry, reaches 50-60% of production costs. These losses suffered in the apparel industry are pieces called 'waste and surplus fabric', and they often do not have any definite commercial value [6]. Therefore, the effects of the CAD system on the cost of fabric, which has the greatest share within the total product cost, were also included into the scope of the research.

For this reason, after the completion of all kinds of work related to patterns, markers were prepared both manually

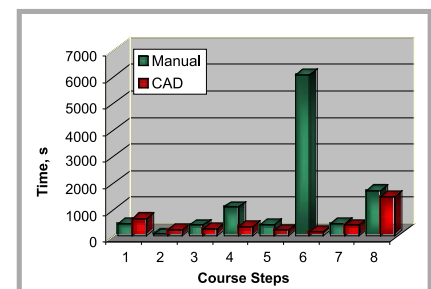

**Figure 6.** Comparison of manual and CAD systems.

and by CAD. If the difficulty of working with cardboard patterns in an area with a minimum width of 85-90 cm and a length of 10-15 m, and the greatness of fabric waste are considered, the convenience and utility of CAD systems in preparing markers can be better understood [14].

At this point, markers were initially prepared by using cardboard patterns on a long table, and replicated five times by five different persons. Then the operators repeated the same procedure on the CAD. The system enables the grain line of the patterns to be parallel to the warp, the pieces to be accurate, and the special restrictions related to patterns determined previously to be properly applied. The results obtained using both methods were compared.

### Evaluation of findings

The Mann Whitney U Test was used to evaluate the findings obtained. The Mann Whitney Test is a method of statistical evaluation which compares the medians of two independent samples, and which is nonparametric. It is used if the two independent groups are the same. This test does not necessitate a normal or near-normal distribution, but it needs the obtainment of the following hypothesis [1].

- Random sampling,
- Independent sampling,
- Independent observations for each sampling.

### Findings and discussion

Time-related data obtained as a result of studies conducted can be seen below in Table 3. As can be seen in this table, the time difference between the manual and CAD methods increases as one moves from Model-1 to Model-4; in other words, from the simple model to the more complicated one.

Figure 5 shows the graph obtained as a result of a comparison between the manual and CAD methods with regard to time-related data for the four models .

At this point, the time values increase in the manual method as one moves from Model-1 to Model-4, whereas the values for the CAD system remain within a close range.

Findings obtained after the data in Table 3 were assessed by the Mann Whitney Test, as shown in Table 4. The 'P'

**Table 3.** Time-related data according to stages for manual and CAD methods (4 Models); Unit time: second.

Number of stage	Model							
	1		2		3		4	
	Manual	CAD	Manual	CAD	Manual	CAD	Manual	CAD
1	585	750	790	470	1,065	590	1,110	435
2	55	110	115	35	110	50	120	45
3	545	165	725	185	1,090	200	955	345
4	1,200	345	1,210	0	1,330	30	1,575	45
5	490	55	245	150	480	170	220	180
6	13,630	115	19,925	150	25,750	90	28,970	140
7	715	325	715	995	780	970	1,055	1,000
8	940	1,640	2,030	1,645	1,705	2,020	2,145	1,380
Total	17,955	3,770	25,450	4,065	32,025	4,590	35,780	3,975
<b>Manual - CAD</b>	<b>+ 14,185</b>		<b>+ 21,385</b>		<b>+ 27,465</b>		<b>+ 31,805</b>	

**Table 4.** Findings obtained as result of assessment of time-related data by Mann Whitney Test (4 Models).

Model	Methods	Statistical data				P
		X	Median	Standard Deviation	Standard Error	
1	Manual	1,816	565	4,170	1,319	0.2413
	CAD	350	140	505	160	
2	Manual	2,575	720	6,128	1,938	0.2123
	CAD	363	122	545	172	
3	Manual	3,231	922	7,933	2,509	0.0963
	CAD	412	100	644	204	
4	Manual	3,615	1,005	8,938	2,826	0.1859
	CAD	357	122	469	148	
Toplam	Manual	28,094	29,032	7,892	3,946	0.0304
	CAD	3,706	3,600	281	140	

**Table 5.** Time-related values based on stages for manual and CAD systems (Model 1); Unit time: seconds.

Number of stage	Methods	Repeats				
		1	2	3	4	5
1	MANUAL	420	460	430	500	440
	CAD	645	585	640	720	570
2	MANUAL	60	65	80	120	55
	CAD	280	25	200	365	200
3	MANUAL	285	305	285	555	545
	CAD	475	155	150	190	355
4	MANUAL	1,110	1,030	990	1,170	1,080
	CAD	275	345	245	480	380
5	MANUAL	210	505	305	575	490
	CAD	205	55	115	465	180
6	MANUAL	5,870	6,000	6,040	6,185	6,255
	CAD	190	115	145	210	70
7	MANUAL	500	530	325	420	470
	CAD	345	150	475	510	445
8	MANUAL	2,440	2,315	915	1,530	1,245
	CAD	1,750	800	1,825	950	1,990
Total	MANUAL	10,895	11,210	9,370	11,055	10,580
	CAD	4,165	2,230	3,795	3,890	4,190
<b>Difference</b>	<b>MANUAL - CAD</b>	<b>6,730</b>	<b>8,980</b>	<b>5,575</b>	<b>7,165</b>	<b>6,390</b>

value was seen to have reached its lowest level in Model 3, which has the longest pattern perimeter due to having long sleeves. It has also been observed that the 'P' value reached its second lowest

level in Model 4, which has the highest number of pieces.

Moreover, in the assessment of total times for all models, where P:0.0304

**Table 6.** Findings obtained as a result of assessment of values by means of Mann Whitney Test (Model 1).

Number of stage	Methods	Statistical data				P P < 0.05	Significant of difference	In favour of method
		X	Median	Standart Deviation	Standart Error			
1	MANUAL	450.0	440.0	31.6	14.1	0.0122	significant	manual
	CAD	632.0	640.0	59.2	26.5			
2	MANUAL	76.0	65.0	26.3	11.8	0.1437	no significant	between the two methods
	CAD	214.0	200.0	125.8	56.2			
3	MANUAL	395.0	305.0	141.8	63.4	0.2101	no significant	between the two methods
	CAD	265.0	190.0	144.2	64.5			
4	MANUAL	1,076.0	1,080.0	69.9	31.2	0.0122	significant	CAD
	CAD	345.0	345.0	92.7	41.4			
5	MANUAL	417.0	490.0	152.8	68.3	0.0367	significant	CAD
	CAD	204.0	180.0	157.2	70.3			
6	MANUAL	6,070.0	6,040.0	152.7	68.3	0.0122	significant	CAD
	CAD	146.0	145.0	56.5	25.3			
7	MANUAL	449.0	470.0	80.3	35.9	0.6761	no significant	between the two methods
	CAD	385.0	445.0	145.0	64.9			
8	MANUAL	1,689.0	1,530.0	667.0	298.0	0.6761	no significant	between the two methods
	CAD	1,463.0	1,750.0	546.0	244.0			
Total	MANUAL	10,622.0	10,895.0	738.0	330.0	0.0122	difference significant	CAD
	CAD	3,654.0	3,890.0	814.0	364.0			

( $P < 0.05$ ), the difference stemming from the comparison of the manual method with CAD has been found to be in favour of CAD.

Time-related data obtained as the result of studies carried out in order to make a comparison of manual and CAD systems is seen in Table 5. An examination of total values of time-related data will reveal the fact that the time periods related to CAD are shorter than those for the manual system. The graph obtained as a result of a comparison of time-related data found for manual and CAD systems in Model 1 is shown in Figure 6.

As can be seen at this point, the situation which was in favour of the manual method in the first, second and third stage has started to change in favour of the CAD method starting from the fourth stage, as the number of sizes and consequently

**Table 7.** Distribution of sizes in marker.

Sizes	XS	S	M	L	XL
Quantities	1	2	3	2	1

**Table 8.** Marker lengths (4 Models).

Models	Lengths, m		
	Manual method	CAD system method	Difference Manual - CAD
1	9.85	9.49	0.36
2	11.60	10.19	1.41
3	15.42	14.36	1.06
4	10.90	9.75	1.15

the patterns to be processed increased, and this continued in the same manner at an increasing pace until the end of the eighth stage.

Findings obtained as a result of assessment of data given in Table 5 by means of the Mann Whitney Test are shown in Table 6 together with the comparison of findings related to the manual method for each stage.

Keeping in mind that one of the most important aims of using CAD is to minimise the waste of fabric, patterns for 4 models were placed on a 120-cm wide fabric using manual and CAD systems, in accordance with distribution of sizes shown in Table 7, markers prepared and marker lengths measured (Table 8).

## Results

In the study, the following results were obtained on the basis of the CAD and manual methods.

In the preparation of main size patterns, the manual system seems to be superior due to the fact that the main size patterns are prepared in advance manually and then digitised. These methods were preferred since the system operators do not have sufficient qualifications.

The results obtained in the first stage are associated with the above mentioned application.

- In steps such as checking, correcting and putting necessary allowances on main size patterns, no significant difference has been found between the two methods, due to effects of personal skills and productivity in particular.
- Since grading main size patterns, checking graded patterns and making arrangements prior to marker making procedures demand manual labour and time, it is only natural for the CAD systems to be advantageous in these steps.
- During marker-making preparation, checking, correcting and plotting procedures, neither method was found to be superior to the other, which was unpredicted.
- In assessing the total times for all stages, the level of significance between the two methods was found in favour of CAD, as predicted.
- When the differences between the marker lengths prepared manually and by CAD are examined, it will be seen that the marker prepared by CAD was shorter even in Model 1, which is the simplest one, and that the difference between the marker lengths prepared manually and by CAD increased in favour of CAD as the number of patterns increased and the size of patterns decreased, which can be seen in the other models.

Making use of CAD helps economise on fabric usage in addition to improving stage times. This clearly shows that CAD

investments are considerable with respect to savings, not only in labour costs but also in fabric usage, which amounts to 60% of total garment costs.

## ■ Recommendations

With the emergence of new global trade environments, alternatives for production and provision of all sorts of goods have increased and competition has become fierce. Nowadays the shelf life of a product is not long enough to justify the time, labour and expense necessary for the design and production manually. This, in turn, makes CAD extremely important for apparel production [3].

The increase in the number and the complexity of the models and the decrease in production time has boosted demands for automatic grading of garment patterns. Automatic preparation of garment patterns using body measurements obtained from body scanning, and furnishing them with fabric and production characteristics, will greatly contribute to the dynamic structure of the apparel sector. Body scanning provides multi-dimensional data that has the potential to provide new insights into sizing and grading systems. However, for body scanning to support automated garment development, automatic integration of measurement data into commercially available CAD/CAM software must be achieved first.

More improvement of the software programmes and training the system operators on pattern making will enable the main size pattern to be prepared from draft; the CAD system will thus become more efficient in the main size pattern stage also. For the CAD system to be more advantageous in the checking and correcting stages of the main size pattern preparation, dependence on individuals in CAD functions should be minimised.

Using the CAD system during marker making as efficiently as in other steps naturally requires the determination of certain standards concerning marker making. Moreover, improving automatic marker making programmes and preparing markers using these programmes followed by necessary corrections will make it possible for the CAD systems to be profitable during these steps as well. Until this objective is realised, some solutions can be offered;

1. The system operator must be qualified in the marker making process.
2. The technician who makes the marker plan and corrections must learn the CAD system.
3. Marker makers who prepare the marker plan according to their previous experience are urged to cooperate and work together with the CAD operator in charge.

The root of the matter lies not only in the selection of the proper CAD system according to the type of the firm and the product, but also in the training of the operators to carry out their functions in the fastest and the most efficient way, and to improve the work standards within the company. Unpredicted problems or results encountered in this research could therefore be attributed to lack of training.

The in-service training programmes of the CAD system companies often fall short of being adequate, because the trainers are not knowledgeable enough to provide training on pattern making and apparel production; the trainees do not have the proper background; they are not technically equipped to function efficiently within the CAD system. Consequently, they fail to reach expected efficiency targets in using the CAD system. For a lasting solution to this problem, it is recommended that the cooperation between the universities and the industrial organizations be promoted in the short term. As a long-term solution, however, it is essential that comprehensive and relevant training programmes be developed, especially at the college level, and that the technicians completing these programmes should be employed in the apparel industry.

In conclusion, the CAD system is much more productive compared to the manual method even in the simplest models, if a system proper to the structure of the firm and the type of product is selected, and if it is used effectively and according to pre-determined objectives. As can be understood from the results of the research, CAD systems will provide great advantages in responding quickly to multi-piece, multi-size orders in small quantities. Moreover, this will provide substantial savings as far as fabric costs are concerned.

## References

1. Akgul, A., 1997, 'Statistical Analysis Technics on Medical Researches-SPSS applications', pp. 276-281.
2. Akgun, K. 1993, 'The Place of Computer Aided Design in Production Phase', *Computer Aided Design and Further Journal*, p. 4.
3. Ashdown S., Loker S., Adelson C., 2001, 'Use of Body Scan Data to Design Sizing Systems Based on Target Markets, National Textile Center Project, Project No. S01-CR01,
4. Broom, H.N., 1967, 'Production Management', Revised Edition, Homewood Illinois, Richard D. Irwin.
5. Carrere C., Istook C., Little T., Hong H., Plumlee T., 2001, 'Automated Garment Development from Body Scan Data, National Textile Center Project, National Textile Center Annual Report: November 2001 Project No. I00-S15.
6. Erdogan, M.C., 1988, 'Organization on Cutting Department of Apparel Companies', SAGEM Conference, Bursa, Turkey.
7. Hands C., Hergeth H., Hudson P., 1997, *International Journal of Clothing Science and Technology*, pp. 154-165.
8. Hearle, J., 1995, 'Arredamento Tekstil Guide' 95, pp.51-54, Boyut Publications, Istanbul.
9. Ikiz F., Puskulcu H., Eren S., 1998, 'Introduction to Statistics', p: 323-324, Izmir.
10. Kaptan, S., 1981, 'Scientific Research Techniques and Statistics Methods' pp. 63-66, Ankara.
11. Liu, Z. and Harlock, C., 1995a, *Textile Research Journal*, January, p: 13.
12. Liu, Z. and Harlock, C., 1995b, *Textile Research Journal*, February, p: 100.
13. Liu, Z. and Harlock, C., 1995c, *Textile Research Journal*, March, p: 162.
14. Ondogan, Z., 1994, 'CAD/CAM Systems in Apparel Industry', *Textile and Apparel Journal*, pp: 406-413, Izmir.
15. Ondogan, Z., 1995, *Textile and Apparel Journal*, pp: 84-86, Izmir.
16. Ondogan, Z., 1997, 'Relevance of apparel companies to computer aided design (CAD), pattern making, model application and marker making systems', PhD. Thesis, Ege University Textile Engineering Department of Engineering Faculty, Izmir.
17. Plumlee T., Eischen J., Bruner D., 2002, '3D Virtual Draping with Fabric Mechanics and Body Scan Data, National Textile Center Project, Project No. F02-S08.
18. REFA, 1988a, 'Work Study Methodology Knowledge-1st Book Fundamentals of Work Study', p.100, Association of Work Study Organization.
19. REFA, 1988b, 'Work Study Methodology Knowledge-2nd Book Fundamentals of Work Study', p.20, Association of Work Study Organization.
20. Tait, N., 1995, *Apparel International*, 26(11), 35-37.



Received 27.07.2004 Reviewed 04.02.2005